









DYNATECH

DIAMONDS AT WORK



2011-2012 DRILLING CATALOG

CONTENTS

	DIAMOND CORE DRILL BITS.....	4
	DRILL RIGS	18
	EXTENSIONS & ADAPTERS.....	31
	ELECTRIC MOTORS.....	32
	HYDRAULIC DRILLING.....	33
	HAND HELD DRILL MOTORS	34
	DRILLING ACCESSORIES	35
	DYNATECH APPAREL.....	45
	CUSTOMER SERVICE POLICIES	46
	ORDER INFO & ORDER FORM.....	47

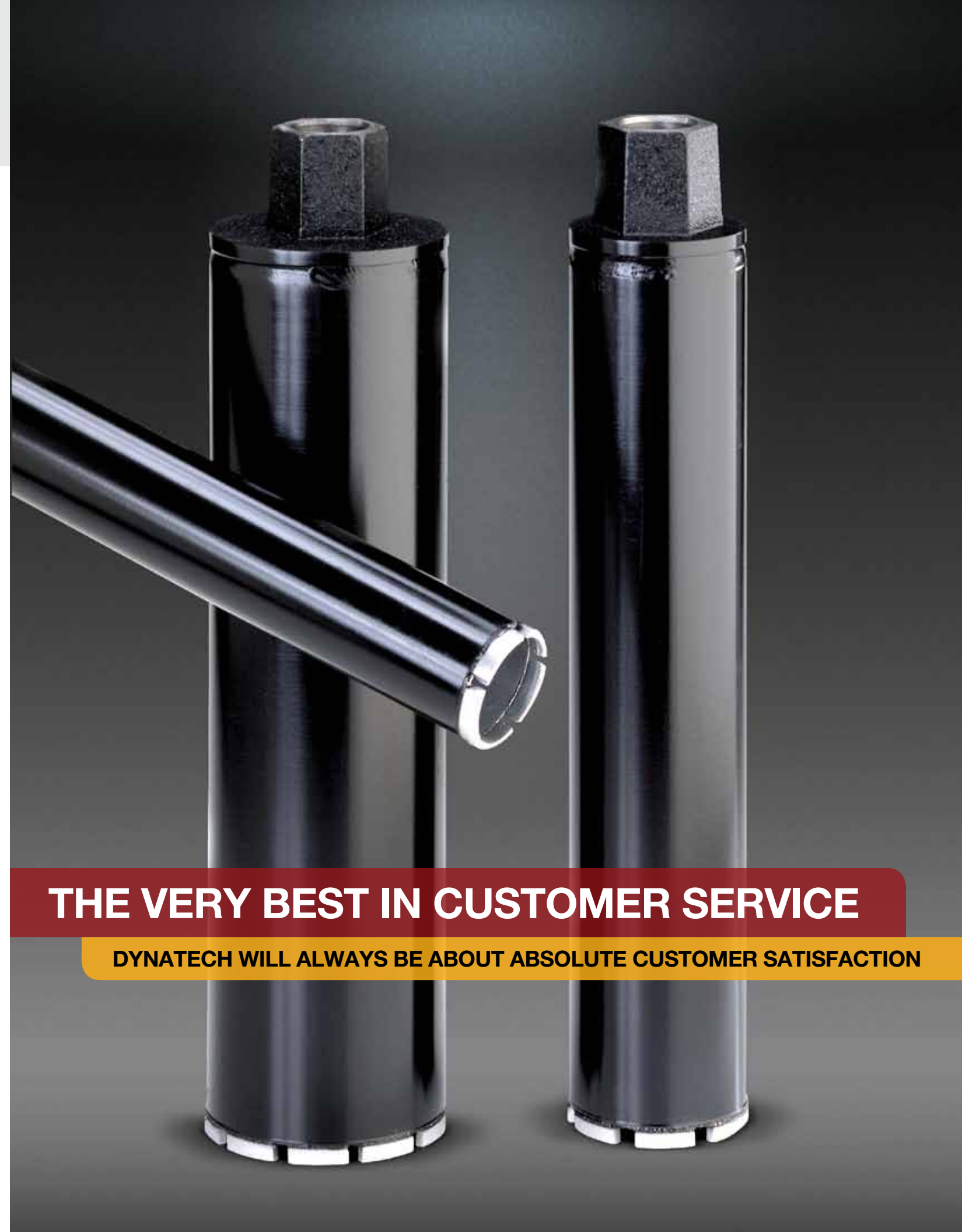

THE VERY BEST IN CUSTOMER SERVICE

DYNATECH WILL ALWAYS BE ABOUT ABSOLUTE CUSTOMER SATISFACTION

DRY DRILLING CORE DRILL BITS

For Brick & Block Walls

For drilling concrete walls or floors see page 8 for wet drilling core drill bits.

Dynatech Regular Dry Diamond Core Drill Bits are ideal when drilling holes in brick and block. The tubes on the diamond bits are slotted to aid in both cooling of the core bit and removal of the cuttings. For years they have been the standard for dry core drilling. Dynatech also offers a starter bit assembly for easier hole starting.

Regular dry diamond core drill bits are for use in brick and block walls only. When drilling concrete walls or floors, use our hand held wet cutting diamond core bit.



ACCESSORIES

12" Long bit extension

6" Long bit extension

1/2" Straight shank adapter

Allows bits to be used in 1/2" rotary (only) drill.



Dynatech Starter Bit assembly makes starting your hole much easier. Assembly is available for use on grinder or 1/2" rotary drill.



BIT SIZES



All sizes of bits can be used with the Rotary Drill using the 1/2" straight shank adapter.



For smaller sizes 1" to 3" a Right Angle Grinder can be used. Bits have 5/8" - 11" female threads so they will screw right on your grinder.

Premium dry hand held diamond core drill bits have a 9" drilling depth. For deeper holes, use either our 6" or 12" long extensions.

Premium DH – Dry Hand-Held Core Bit

Bit (OD) Diameter	Drill/Grinder Min/Max RPM	Min. Amps	Price	P/N
7/8" DH	2300/6000	6	\$64	
1" DH	2300/6000	6	66	
1 1/4" DH	2300/6000	6	71	
1 1/2" DH	1600/5000	7	81	
1 3/4" DH	1600/5000	7	89	
2" DH	1600/5000	7	99	
2 1/4" DH	1600/5000	7	119	
2 1/2" DH	1600/5000	7	129	
3" DH	1600/5000	7	139	
3 1/2" DH	800/1200	10	149	
4" DH	700/1200	10	159	
5" DH	700/1000	10	169	
6" DH	600/1000	10	199	
1/2" Straight shank adapter			\$18	4400033
6" Long bit extension			32	4400003
12" Long bit extension			38	4400005
Carbide Starter Bit			15	4400012
Starter Bit Adapter			28	4400035

(Bit diameters given are o.d.)



VACUUM DRY DRILLING CORE DRILL BITS

For Brick, Block & Some Concretes*

Dynatech Vacuum Dry Drill Bits are an inexpensive and fast way to drill holes in brick, block, and some concrete.* Perfect for situations where water cannot be used or when dust control is a factor. Simply screw the vacuum swivel on your grinder or 1/2" drill, connect your vacuum hose from any vacuum source (shop vac, wet/dry vac etc.) and you are ready to drill. The vacuum suction pulls air down the outside of the bit and across the diamond segments. This aids in cooling, and removes cuttings quickly so that the new cuttings can be created. Fast removal of cuttings eliminates bit binding, provides faster cutting and produces longer bit life.

**For hard concrete or concrete with steel reinforcing (Rebar) use Dynatech Wet Cutting Core Bits*



ACCESSORIES

		P/N
Air vacuum Swivel	\$149	4400125
12" Long vacuum bit extension	38	4400126
1/2" Straight shank adapter	18	4400033

Allows bits to be used in 1/2" rotary (only) drill.

BIT SIZES

Premium DV – Dry Vacuum Core Bit

Bit (OD) Diameter	Drill/Grinder Min/Max RPM	Min. Amps	Price
1 1/2"	1600/5000	7	\$81
1 3/4"	1600/5000	7	89
2"	1600/5000	7	99
2 1/4"	1600/5000	7	119
2 1/2"	1600/5000	7	129
3"	1600/5000	7	139
3 1/2"	800/1200	10	154
4"	700/1200	10	159
5"	700/1000	10	169
6"	600/1000	10	199

(Bit diameters given are o.d.)



Right Angle Grinder

Can be used for smaller bit sizes (1 1/2" to 3").



Rotary Drill

Can be used for all bit sizes.



FACT

Dynatech Premium Core Bits contain more diamond segments and diamond content than any other bit made.

WET DRILLING HAND HELD CORE DRILL BITS

For Brick, Block & Reinforced Concrete

Dynatech Wet Cutting Hand Held Core Drill Bits are especially designed for hand held drilling applications.* Made with a thinner diamond kerf than our rig mounted core bits, these bits produce less drag and resistance during drilling. These core bits also allow faster penetration in concrete with reinforced steel. This faster drilling combined with 30 percent less weight allows for less operator fatigue and a more profitable operation. Dynatech Hand Held Wet Core Drill Bits are also excellent for use on the Pro 4 Core Drill Machine.

Simply screw the wet cut swivel onto your grinder or 1/2" drill, connect your water hose and you are ready to drill.



Wet cutting bits are for use in most all materials such as hard concrete, reinforced concrete (rebar), brick and block. Can be used in both walls and floors.

NOW AVAILABLE
**"HOW TO"
DRILLING VIDEO**
www.dynatech-diamond.com

BIT SIZES

Bit Diameter	Price	Bit Diameter	Price
1/2" WH	\$69	2 1/4" WH	\$129
5/8" WH	74	2 1/2" WH	139
3/4" WH	76	2 3/4" WH	154
7/8" WH	78	3" WH	165
1" WH	86	3 1/4" WH	174
1 1/8" WH	90	3 1/2" WH	179
1 1/4" WH	94	3 3/4" WH	192
1 3/8" WH	98	4" WH	195
1 1/2" WH	102	4 1/4" WH	214
1 5/8" WH	106	4 1/2" WH	249
1 3/4" WH	108	5" WH	278
1 7/8" WH	114	5 1/2" WH	292
2" WH	119	6" WH	297

(Bit diameters given are o.d.)

Premium WH –
Wet Hand-Held Core Bit

In Stock Size Chart

ANY size or length core bit can be made, usually with one or two day turn around time.

*All core bits have 5/8"-11 threads and come stock with 13" drilling depth. Longer or shorter bits available on request.

ACCESSORIES

		P/N
Wet cut swivel	\$149	4400014
6" Long bit extension	32	4400003
12" Long bit extension	38	4400005
1/2" Straight shank adapter	18	4400033



Weka DK-13 Drill Motor – \$1,390
3 Speeds, slip clutch and built-in water swivel.

DIAMOND CORE DRILL BITS

DIAMOND CORE DRILL BITS

WET DRILLING CORE DRILL BITS

For use on any core drilling machine

#1 SELLING DIAMOND CORE BIT!

Dynatech Wet Cut Diamond Core Drill Bits are made for use on core drill machines. From hard concrete with steel reinforcing to easier to drill materials such as asphalt, brick, and block. Dynatech wet cut diamond core bits provide fast, trouble free drilling and give a long service life. All Dynatech Wet Cut Core Drill Bits are made with a maximum diamond concentration and are available in Premium Grade only.

All sizes listed are stocked with a 13" drilling capacity. Deeper holes can be drilled by using Dynatech bit extensions. Dynatech can also make your bits as long or as short as needed. All wet cutting bits 1 5/8" o.d. and larger come stock with 1 1/4" -7 thread - 1 1/2" o.d. and smaller bits come stock with 5/8"-11 thread welded in adapter. Dynatech core bit adapters can adapt any size bit to any size thread.



Dynatech specializes in custom-made bits of any size and any type application. If you need it, we will make it.



FACT
Dynatech Premium Core Bits contain more diamond segments and diamond content than any other bit made.

BIT SIZES

Bit Diameter	Price	Bit Diameter	Price
1/2"	\$69	3 1/2"	\$179
5/8"	74	3 3/4"	192
3/4"	76	4"	195
7/8"	78	4 1/4"	214
1"	86	4 1/2"	249
1 1/8"	90	5"	278
1 1/4"	94	5 1/2"	292
1 3/8"	98	6"	297
1 1/2"	102	7"	392
1 5/8"	106	8"	415
1 3/4"	108	9"	498
1 7/8"	114	10"	540
2"	119	12"	726
2 1/4"	129	14"	969
2 1/2"	139	16"	1045
2 3/4"	154	18"	1187
3"	165	20"	1349
3 1/4"	174	24"	1639

(Up to 72" o.d. Call for pricing.)

ACCESSORIES

Bit	Price	P/N
6" long bit extension 5/8" thread (For bit sizes 1/2" to 1 3/4")	\$32	4400003
12" long bit extension 5/8"-11 thread (For bit sizes 1/2" to 1 3/4")	38	4400005
6" long bit extension 1 1/4"-7 thread (For bit sizes 1 3/4" and larger)	36	4400004
12" long bit extension 1 1/4"-7 thread (for bit sizes 1 3/4" and larger)	44	4400006
ADAPTERS:		
1 1/4"-7 Female thread to 5/8"-11 Male thread	42	4400008
5/8"-11 Female thread to 1 1/4"-7 Male thread	49	4400009

Premium WR –
Wet Rig Core Bit

In Stock Size Chart

Any size diameter (up to 60" o.d.) or length core bit can be made, usually with one or two day turn around time.

**All wet core bits 1 1/2" and smaller have 5/8"-11 thread - wet core bits 1 5/8" and larger have 1 1/4"-7 thread. All come stock with 13" drilling depth. Any size diameter, length, or thread can be made.*



M-1 Complete Combination Rig - \$2316
(with 20 amp DeWalt) P/N 4245055

THREADED BITS, BARREL EXTENSIONS & THREADED CAPS

Need to drill a really deep hole? 5 feet, 10 feet or even 50 feet deep? Holes OD sizes from 1" to 10" OD. Threaded bits

have 12" drilling depth. Threaded barrel extensions come in 12", 24", 36" and 48" lengths.



Prices

Bit Diameter	Premium Core Bit	1 1/4" - 7 Threaded Cap	12" Core Barrel Extension	24" Core Barrel Extension	36" Core Barrel Extension	48" Core Barrel Extension
1"	\$124	\$40	\$48	\$58	\$70	\$80
1 1/4"	140	44	52	62	74	86
1 1/2"	155	46	54	68	78	92
2"	170	50	60	74	82	96
2 1/4"	180	55	64	78	88	102
2 1/2"	200	65	70	84	96	116
2 3/4"	210	70	74	86	98	118
3"	230	75	78	90	105	120
3 1/4"	250	80	82	94	110	130
3 1/2"	260	85	90	98	115	135
4"	290	90	92	102	120	145
4 1/2"	350	95	98	126	165	205
5"	370	98	102	130	176	220
5 1/2"	400	104	108	138	190	235
6"	440	105	112	142	210	250
6 1/2"	480	110	216	310	370	435
7"	540	115	240	320	390	465
8"	560	130	260	330	410	480
9"	650	155	310	410	490	640
10"	700	160	290	380	470	565

.187 wide diamond kerf

.250 wide diamond kerf

SPECIALTY BITS

We Make Special Custom Bits

Dynatech makes a wide variety of specialty core bits, including everything from "Step" Bits to "Pancake" Bits and more!

Got a unique coring application? We can create a custom bit that precisely matches your coring job. We can turn any custom job around within one to two days.



Carbide Rebar & Plate Cutters

Designed to cut through rebar or plate steels after a diamond core bit has drilled through the concrete. Carbide inserts are brazed into the core barrel. This specialized bit must be used with water to keep the bit cool while drilling in steel.



Pancake Bits

For use in applications where a hole is needed with a recessed top. Great for airport runway light canisters. Most custom sizes and bonds available.

Dry Bit for Tile

Features centering bit for straight, smooth holes.

- Dry bit allows 1-1/4" depth of cut.
- 5/16" shank diameter



DRY BIT FOR TILE

Size Inches (mm)	P/N	Price
1 (25)	681802	\$36
1-1/8 (29)	684100	37
1-1/4 (32)	684101	38
1-3/8 (35)	684018	39
1-1/2 (38)	684102	43
1-5/8 (43)	681814	45
1-3/4 (44)	684103	47
2 (51)	681815	49



Step Bits

Designed to make a recessed 'step' for drain covers, etc. Custom sizes available.

MARBLE & GRANITE DIAMOND BITS

- Small diameter bits made just for natural stone
- Crown-style for smooth, clean cut
- 3" core length with 5/8"-11 threaded hub
- P28Z - Premium Black bond for long life in hard materials like marble and granite
- Recommended for wet cutting

Diamond bits have 5/8"-11 female threads and are made to screw on the wet cut swivel or a grinder. When using a rotary drill use one of these adapters.



3/8" Straight Shank to 5/8"-11 Threaded Adapter
\$18 P/N 4400056



1/2" Straight Shank to 5/8"-11 Threaded Adapter
\$18 P/N 4400033



5/8" Straight Shank to 5/8"-11 Threaded Adapter
\$18 P/N 4400087



357HD Water Swivel 5/8"-11 to 5/8"-11 with Water Valve
\$149 P/N 4400014

Premium Black Natural Stone Bits

Size (with 3" core)	CAT #	Price
1"	28026	\$76
1-1/4"	28027	99
1-3/8"	28029	102
1-1/2"	28033	104
1-3/4"	28034	119

NON-CORING BITS

N25 NCB Non-Coring Bits

These core bits are designed to drill holes through all kinds of granite and highly recommended for wet drilling. For installing anchors.



Diameter & Width	Part No.	Price
1/4"	D30001	\$52
5/16"	D30004	56
3/8"	D30002	59
1/2"	D30003	67

Non-coring Bit Specs

Drilling Length	2"
Thread Size	5/8"-11

WATER TRAP RINGS



- Self-attaching ring for water containment during core drilling on all types of stone, tile and glass.
- Includes two rings: a small ring for faucet opening holes up to 1-1/2" and a large ring for sink opening holes up to 3".
- Made of pliable rubber with a special lip that creates a suction to firmly hold in place while drilling and can be used repeatedly.
- Reduces slurry splash and clean up time.

Diameter	Part No.	Price
1-1/2" & 3"	542173523	\$12.96

CARBIDE TIPPED CORE BITS

For Drilling Applications with Heavy Steel Rebar



Carbide plate cutters for use in plate steel

REBAR CUTTING CORE BITS

DIAMETER	CAT # Rebar Cutters	# of Inserts	Price
1/2"	07253	4	\$94
5/8"	07256	4	97
3/4"	07257	4	100
7/8"	07259	4	103
1"	07236	4	106
1-1/8"	07237	4	100
1-1/4"	07238	6	119
1-3/8"	07239	6	130
1-1/2"	07240	6	140
1-5/8"	58064	6	148
1-3/4"	07241	6	150
1-7/8"	07242	6	156
2"	07243	8	163
2-1/2"	07248	10	168
3"	07249	10	225
3-1/2"	07250	14	242
4"	07252	16	264
5"	07254	18	373
6"	07255	24	442

PLATE CUTTING CORE BITS

DIAMETER	CAT# Plate Cutters	# of Inserts	Price
1/2"	59195	4	\$102
5/8"	49514	6	103
3/4"	49515	6	104
7/8"	52040	8	109
1"	07260	10	115
1-1/8"	07262	12	122
1-1/4"	07263	12	136
1-3/8"	61081	12	140
1-1/2"	07265	14	171
1-5/8"	62663	14	184
1-3/4"	07266	16	192
1-7/8"	55705	16	194
2"	07267	20	196
2-1/2"	07269	22	220
3"	07270	24	265
3-1/2"	62429	32	294
4"	07273	34	307
5"	43399	36	466
6"	07275	38	636

Retractable Carbide Walker Duct Bits

Allows drilling of concrete and metal duct in one operation.



RETRACTABLE CARBIDE BITS

Description	Catalog No.	Price
2-1/4" x 2-1/2" Retractable Carbide Diamond bit (complete assem.)	01673	\$359
2-1/4" Carbide Hole Saw	00032	98
2-1/2" x 8" HOL Threaded Bit	05252	161
Threaded Shaft Adapter	01929	79
2-1/2" Left/Right Threaded Cap	01928	28



Pre Cast Bits

Precast core bits have shorter segment length and are closely spaced together to help prevent seg loss in precast materials with wire mesh and pre-tensioned wire.

PREMIUM PRE CAST BITS

Size	POL CAT #	Price	Size	POL CAT #	Price
1"	41226	\$70	4"	41234	\$211
1-1/4"	41227	90	4-1/2"	41235	273
1-1/2"	41228	94	5"	41236	298
1-3/4"	41229	112	6"	41237	359
2"	41230	119	7"	41238	485
2-1/2"	41231	133	8"	41239	499
3"	41232	171	9"	41240	590
3-1/2"	41233	189	10"	41241	630



DIAMOND CORE DRILL BITS

DIAMOND CORE DRILL BITS

M-1 DRILL RIG

Most Popular Selling Drill Rig

- 1" to 10" bit capacity (14" with one spacer)
- Dual switch/outlet control panel & amp meter
- Slide handle permits drilling in tight areas
- Streamlined base and carriage
- 2-1/2" square column with black oxidized finish
- Quick changeover from vacuum to anchor base
- 6" wheels for better mobility

Order Complete as shown \$2316

Our Combination rig includes a combination anchor/vacuum base, mast, carriage, control panel, vacuum pump, ceiling jack, motor mount plate and your choice of Core Bore, (DeWalt) or Milwaukee 20 amp drill motor. Our anchor rig is same as above except for its smaller anchor base and does not include a vacuum pump.



M-1 Complete Combination Rig
(20 amp CB748 - P/N 4245055)
\$2316 Complete Rig

ELECTRIC MOTORS



CB748
(Black & Decker
DeWalt style)
20 AMP
P/N 4244000



Milwaukee
Wide variety of
models are
available

Motor	AMP	RPM	Safety Override	P/N	Price
CB 748 (B&D DeWalt)	20	350/900	Slip Clutch	4244000	\$1204
Milwaukee Model 4004	20	300/600	Slip Clutch	4244032	1169
Milwaukee Model 4096	20	450/900	Slip Clutch	4244038	1169
Milwaukee Model 4005	20	600/1200	Slip Clutch	4244042	1169

CONTROL PANELS



Optional On/Off Switch
for all motors
110V P/N 4244021 **\$54**



Vacuum Hold Down Pump with fittings
Mount easily and run quietly
110V P/N 4244075 **\$259**



Dual Switch/Dual Outlet w/Amp Meter
With 3 red lines; 15, 18, 20 amp
110V P/N 4243000 **\$177**

M-1 COMPLETE DRILL RIGS

Motor	RPM	Safety Override	Complete Combination Rig P/N (Includes vacuum hold down)	Price	Complete Anchor Rig P/N	Price
20 Amp Core Bore CB748	350/900	Slip Clutch	4245055	\$2316	4545001	\$1957
20 Amp Milwaukee	300/600	Slip Clutch	4245048	2212	4245009	1853
20 Amp Milwaukee	450/900	Slip Clutch	4245059	2212	4245003	1853
20 Amp Milwaukee	600/1200	Slip Clutch	4245049	2212	4245010	1853

Or, Build Your Own:

Select one of the drill stands shown below, add drill motor, control panel/on-off switch, and vacuum pump as required for your application. Drill stands include base, mast*, carriage, ceiling jack and motor mount plate.

* Call factory for special length masts.

Combination Drill Stand Only*		Anchor Drill Stand Only*	
Combination Standard P/N 4245065	Combination Angle P/N 4245062	Anchor Standard P/N 4246055	Anchor Angle P/N 4246070
\$639 	\$774 	\$539 	\$681

* Motor mount (part no. 4648004) required if using a WEKA drill motor with M-1 combination or M-1 drill stand.

Location to drill anchor hole:
12" = M-1 Combo Rig; 12-1/2" = M-1 Anchor Rig
Measured from the center of the motor spindle to the center of the anchor/vacuum slot on the rig base.

M-1 DRILL STAND DIMENSIONS

	Anchor	Combination
A.	43-3/4"	44-1/4"
B.	24-1/2"	24-1/2"
C.	5-5/8"	5-5/8"
D.	3-1/2"	2-1/2"
E.*	11"	17"
F.	16"	23"
G.	6"	13-1/2"
H.	23-1/2"	18-1/2"

* For CB748 motor

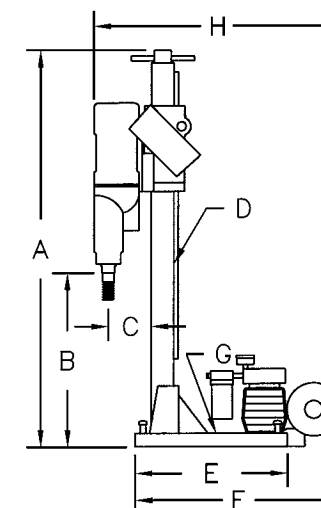

Need help selecting the rig that's just right for your job? Call us, we'll help you select just the right machine!

1-800-446-9001
WWW.DYNATECH-DIAMONDS.COM

M1-AA-15 DRILL RIG

Convenience and Durability in a Light Weight Rig

Perfect for the occasional user

- 6 inch bit capacity
- Weighs only 45 lbs.
- 15 amp, 3.5 HP Core Bore Motor
- Single speed - 800 RPM
- Very durable and reliable
- Water hose connection
- Spring loaded slide handle for easy coring
- Convenient carrying handle on carriage
- Includes a water trap ring



Vacuum Hold Down Plate Base Assembly w/wheels
for vacuum core drilling (optional)
P/N 4247075
\$220

Vacuum Pump w/fittings
P/N 4244075
\$259



Water Trap Ring
(Standard w/drill rig)
P/N 2704100
\$82



M1-AA-15 Complete Drill Rig as shown \$912
15 amp, 3.5HP
P/N 4220050 Cat. No. 85986

M1-AA-15 DIMENSIONS

	Size
A.	30"
B.	15"
C.	6-7/8"
D.	21"
E.	5-1/4"
F.	8-1/2"

Location to drill anchor hole: 9-1/2"
Measured from the center of the motor spindle to the center of the anchor/vacuum slot on the rig base.

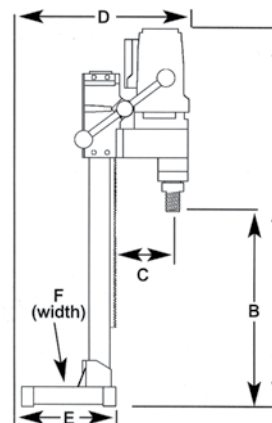

M-180 DRILL RIG

High Performance in a Compact Machine

Perfect for the frequent user

- Lightweight core drill rig for the rental shop or professional who requires high performance in a compact machine
- For angle drilling
- 6" maximum bit capacity
- Single-speed gearbox and electric overload protection
- Mechanical clutch reduces risk of motor damage
- 19" drilling stroke
- Handle for portability
- V-groove roller carriage for accurate alignment that requires minimal adjustment

TECHNICAL SPECIFICATIONS

Power	1,725W
Voltage/amperage	110/15
Max bit diameter, in. (mm)	6 (152)
Travel length, in. (mm)	19 (483)
Spindle speed full load	540 rpm
Weight, lbs (kg)	51 (23.3)



Slider Bit Quick Disconnect 1-1/4"
for easy bit removal
P/N 541400280
\$59



M-180 Drill Rig \$995
Bit sold separately

M-2 DRILL RIG

Professional Heavy Duty

The M-2 is the number one choice of professional core drillers. The larger mast (2-7/8") is precision ground and chrome plated for strength and ease of drilling. The base and carriage are built even stronger to withstand the load larger bits can put on a drill rig. If you are a contractor who drills a lot of holes, large or small, and wants a drill rig that can drill holes up to 36" in diameter, the M-2 is your rig.

- Dual switch/outlet control panel & amp meter
- 4 Spoke Handle
- Precision ground & chrome plated 2-7/8" square mast
- Quick changeover from vacuum to anchor base
- 10" bit capacity (up to 36" with spacers and a hydraulic motor and pillow block)
- 6" wheels for better mobility
- For holes 16" and larger, see page 21 for motor and pillow block info.

Order Complete - as shown \$2608

Our Combination rig includes a combination anchor/vacuum base, mast, carriage, control panel, vacuum pump, ceiling jack, motor mount plate and your choice of CB 748 20 amp or Milwaukee 20 amp drill motor.



M-2 Complete Combination Rig
(23 amp WEKA - P/N 4241068)

ELECTRIC MOTORS



CB748
(replaces B&D and DeWalt)
P/N 4244000



WEKA DK42/DK42S
Very powerful, 3 phase, 220V
P/N 4244022



Milwaukee
Wide variety of
20 amp models
P/N 4244032



WEKA DK22/DK22S
23 amp, 2 speed, 110V
P/N 4244014

Motor	AMP	RPM	Safety Override	P/N	Price
CB 748	20	350/900	Slip Clutch	4244000	\$1265
Milwaukee Model 4004	20	300/600	Slip Clutch	4244032	1169
Milwaukee Model 4096	20	450/900	Slip Clutch	4244038	1169
Milwaukee Model 4005	20	600/1200	Slip Clutch	4244042	1169

Professional Heavy Use Drill Motors:

WEKA DK22	23	300/640/960	Slip Clutch	4244018	1999
WEKA DK22	11 (2 20V)	300/640/960	Slip Clutch	4244016	1999
WEKA DK22S	23	420/880/1300	Slip Clutch	4244014	1999
WEKA DK22S	11 (220V)	420/880/1300	Slip Clutch	4244029	1999
WEKA DK42	6 amp 460V-3PH	190/410/610	Slip Clutch	4244022	2599
WEKA DK42	13 amp 230V-3PH	200/420/630	Slip Clutch	4244023	2599
WEKA DK42S	6 amp 460V-3PH	290/605/910	Slip Clutch	4244027	2599
WEKA DK42S	13 amp 230V-3PH	290/610/910	Slip Clutch	4244024	2599

Or, Build Your Own:

Select one of the drill stands shown below, add drill motor, control panel/on-off switch, and vacuum pump as required for your application. Drill stands include base, mast*, carriage, ceiling jack, motor mount plate. * Call factory for special length masts or see page 25 for mast information.

Vacuum & Anchor Combination Drill Stand		Anchor Only Drill Stand		Large Anchor Only Drill Stand
Combination Standard P/N 4241055	Combination Angle P/N 4241056	Anchor Standard P/N 4241100	Anchor Angle P/N 4241110	P/N 4241064
				
\$930	\$1186	\$819	\$1071	\$930

M-2 DRILL STAND DIMENSIONS

Anchor	Combo	Lg Anchor
A. 44"	44"	44"
B. 23-3/4"	28-1/2"	27"
C. 7"	13-1/2"	15"
D. 23-1/2"	23-1/2"	23-1/2"
E. 5-1/2"	5-1/2"	5-1/2"
F. 12-1/4"	17"	18-1/2"
G. 17-1/4"	23"	20-1/2"

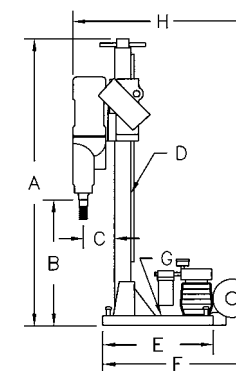

Vacuum Pump
Mount easily, run quietly
110V p/n 4244075 \$259
220V p/n 4244076 312



Dual Switch/Dual Outlet Amp Meter
With 3 red lines: 15, 18, 20 amp
110V p/n 4243000 \$177
220V p/n 4243075 209

M-3 STAIR RIG

Small Drill rig for Tight Spaces

Shown with removable hand-held WEKA motor

A light weight and economical drill rig, the M-3 is an ideal rig for drilling holes for stair railing. The compact size lets you mount this rig on an 8" wide step.

- Single switch/outlet control panel & amp meter
- Slide handle permits drilling in tight areas
- Mast swivels 360° in combination base
- 1-1/2" square mast
- 1/2" to 6" bit capacity
- Compact size for hard-to-access location drilling

Our Combination rig includes a combination anchor/vacuum base, mast, carriage, control panel, vacuum pump, ceiling jack, motor mount plate and Weka DK-13 drill motor. Our anchor rig is the same as above except for its smaller anchor base and does not include vacuum pump. Select from P/N's listed below.

Or, Build Your Own:

Select one of the drill stands shown at left, add drill motor, control panel/on-off switch, and vacuum pump as required for your application. Drill stands include base*, mast**, carriage, ceiling jack, motor mount plate.

* Anchor stand includes wheels.

** Call factory for special length masts or see page 25 for mast information.



M-3 Complete Combination Rig \$2718
Includes vacuum hold down, single switch control panel, M-3 rig and WEKA drill motor
P/N 4247400

M-3 DRILL STAND DIMENSIONS

	Anchor	Combination
A.	35-1/2"	35-1/2"
B.	14"	17-3/8"
C.	4-7/8"	4-7/8"
D.	29-3/8"	29-3/8"
E.	10"	12"
F.	6-3/4"	8"

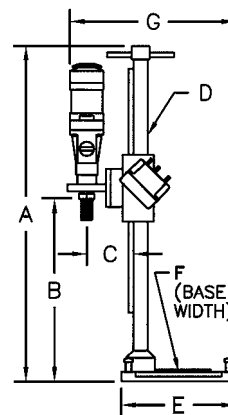

P/N 4247540
\$474

P/N 4247547
\$506



ELECTRIC MOTORS

M-3 Rig is available with these motors...

1-800-446-9001
WWW.DYNATECH-DIAMONDS.COM



WEKA DK13
Hand held and portable
P/N 4244062



CB748
(replaces Black & Decker)
P/N 4244000



Milwaukee
20 amp
P/N 4244032

Motor	AMP	RPM	Safety Override	P/N w/out Switch	Price	P/N with Switch	Price
WEKA DK13	14	580/1400/2900	Slip Clutch	---	---	4244062	\$1390
WEKA DK12	7 (220V)	580/1400/2900	Slip Clutch	---	---	4244013	1390
CB 748	20	350/900	Slip Clutch	4244000	\$1265	4244005	1304
Milwaukee 4004	20	300/600	Slip Clutch	4244032	1136	4244033	1169
Milwaukee 4096	20	450/900	Slip Clutch	4244038	1136	4244039	1169
Milwaukee 4005	20	600/1200	Slip Clutch	4244042	1136	4244043	1169



WEKA DK-13 Drill Motor
P/N 4244062
\$1390

Use the WEKA drill motor hand held or slip it into the M-3 drill stand. Either way, this versatile drill motor is a top performer.



Note:
Weka Motors come with case included in price.
Extra case \$69
P/N 2701483

CONTROL PANELS



Single Switch/Dual Outlet Amp Meter
With switch, controls motor outlet and vacuum pump outlet. Amp meter, has three red lines; 15, 18, 20 amp.

110V	P/N 4277537	\$166
220V	P/N 4277538	199



Optional On/Off Switch
for CB748 or Milwaukee motors

110V	P/N 4244021	\$54
220V	P/N 4243021	54

M-4 RIG

Compact hand Held Unit Turns Into Drill Rig

3 speed, very powerful and just 35 pounds, the M-4 is now available with swivel and anchor bases for added drilling versatility. The M-4 Drilling Machine is the most popular rig for drilling holes 6" and smaller in both floors and walls. At just 35 lbs. it's easy for just one person to mount this rig to a wall and drill. The Weka DK-13 Hand Held Drill Motor is easy to remove from the M-4 rig and can handle all your handheld drilling needs. the Weka DK-13 can be used to drill dry holes in walls or wet cutting in reinforced concrete.

- Weighs only 35 lbs. (rig -20 lbs., motor -15 lbs.)
- 6" bit capacity
- Converts to hand held drill motor in seconds
- Combination Stand quickly angles to 45 degrees
- 3-speed hand held drill motors with overload clutches are available with choice of 110V electric, 220V electric, air or hydraulic power
- Mast can rotate 360 degrees on swivel stand
- Reversible slide handle (use on left side or right side of rig)
- High strength, hard anodized, 1-1/2" x 2" aluminum column
- 4 adjustable slide bearings provide superior carriage rigidity
- Carriage Lock



WEKA DK13 Hand Held Drill
580/1400/2900 RPM
P/N 4244062 \$1290



Vacuum Pump and fittings
P/N 4244077 \$284



- A. Reversible slide handle
- B. Carriage Lock
- C. Adjustable slide bearings
- D. Handheld motor quick release



- A. Centering pointer
- B. Lifting handle
- C. Quick vacuum release valve
- D. Locking slot cap
- E. Depth stop



M-4 Combination Rig \$1932

(Shown with 14 amp WEKA - P/N 4240044) And Combo Stand P/N 4240020

less vacuum hold down system

M-4 DRILL RIG DIMENSIONS

Combo Stand

- A. 33-1/8"
- B. 19-3/4"
- C. 7-7/8"
- D. 21-3/8"
- E. 3-5/8"
- F. 16-7/8"

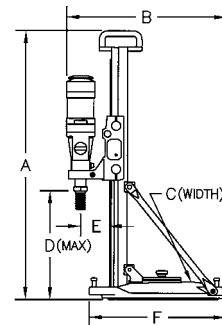

COMPLETE M-4 COMBINATION DRILL RIGS WITH VACUUM HOLD DOWN

Motor	RPM	Combo Rig P/N	Price
14 Amp WEKA DK13	580/1400/2900	4240044	\$2497
15 Amp Milwaukee	500/1000	4240002	2074
20 Amp Milwaukee	300/600	4240004	2074
20 Amp Milwaukee	450/900	4240005	2074
20 Amp Milwaukee	600/1200	4240006	2074
7 Amp WEKA DK12 (220V)	580/1400/2900	4240009	2661

NEW! M-4 COMPLETE ANCHOR DRILL RIGS

Motor	RPM	Combo Rig P/N	Price
14 Amp WEKA DK13	580/1400/2900	4240045	\$1950
15 Amp Milwaukee	500/1000	4240011	1730
20 Amp Milwaukee	300/600	4240013	1750
20 Amp Milwaukee	450/900	4240014	1750
20 Amp Milwaukee	600/1200	4240015	1750
7 Amp WEKA DK12 (220V)	580/1400/2900	4240016	2260

NEW! M-4 COMPLETE SWIVEL DRILL RIGS WITH VACUUM HOLD DOWN

Motor	RPM	Combo Rig P/N	Price
14 Amp WEKA DK13	580/1400/2900	4240030	\$2497
15 Amp Milwaukee	500/1000	4240031	1987
20 Amp Milwaukee	300/600	4240033	1987
20 Amp Milwaukee	450/900	4240034	1987
20 Amp Milwaukee	600/1200	4240035	1987
7 Amp WEKA DK12 (220V)	580/1400/2900	4240036	2622

Slip Clutch Safety Override on all of the above rigs.

Swivel Stand
P/N 4240028
\$552



Anchor Stand
P/N 4240024
\$524



Simple angle adjustment shown using a combination stand



M-4 Combination Stand
P/N 4240020 \$642



Convenient WEKA Carrying Case
P/N 2701483 \$69

M-6 DRILL STAND

Got Big Holes to Drill?

Quit wrestling with big bits on small rigs, the M-6 can handle them for you. The M-6 Rig makes drilling large diameter holes faster and safer.

- 2:1 gear reduction makes easy lifting of larger bits
- 18-inch bit capacity with standard pillow block
- Optional 4"x6" steel tube spacers for drilling up to 72" diameter holes
- Available hydraulic pillow block and extensions with 1-7/8"-7 or 1-1/4"-7 threads for high torque drilling
- Heavy duty 15" x 12" roller carriage
- Equipped with a beefy 72" tall 4" x 6" rectangular mast
- Sturdy cast aluminum base
- 6-inch rubber tread cast-iron wheels with roller bearings



Convenient drop-in quick disconnect motor mount.



M-6 DRILL STAND	
Height	72", 96" or 120"
Length	23"
Width	19" (wheel to wheel)

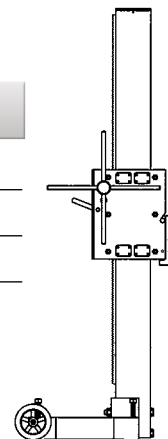

- A. Quick releasing carriage lock
- B. 1:1 and 1:2 rack & pinion design
- C. Eccentric roller adjusters

M-6 Large Bit Drilling System - \$4509

Shown with drill stand, tube spacer, hydraulic pillow block, hydraulic motor and bit extension. (Diamond bit not included)

M-6 Drill Stand Only - \$2507

Large anchor stand with wheels and quick disconnect motor mounted plate. P/N 4277581

Please note that the Pillow Block and hydraulic motor must be ordered separately. Use P/N 4277539 for 1-1/4"-7 spindle. Use Pillow Block P/N 4277540 for 1-7/8"-7 spindle for use on bits 30" and up. See opposing page for hydraulic motor choices



M-6 Large Bit Drilling System shown with a 48" dia. x 36" long diamond bit.

Need help choosing the right motor?

To order a hydraulic motor choose the line with the GPM closest to your hydraulic power unit. Find the RPM needed for your drilling application and go to the Cu. In. line of the chart where you will find the motor size and its part number.

RECOMMENDED RPM'S FOR VARIOUS BIT SIZES							
Bit Diameter	1"	2"	3"	4"	6"	8"	10"
Recommended RPM	3200	1600	1050	800	530	400	320
Bit Diameter	12"	14"	18"	20"	24"	36"	42"
Recommended RPM	265	225	175	160	130	85	75

HYDRAULIC MOTOR RPM DATA - MAXIMUM RPM VALUES WITH VARIOUS CUBIC INCH DISPLACEMENT/GPM COMBINATIONS

Danfoss	Char-Lynn												White		
	Cu. In.	.7	1.1	1.5	1.9	4.9	6.2	8.0	9.6	11.9	14.9	18.7	24.0	32.0	45.6
GPM	4250012	4250013	4250014	4250015	4250008	4250007	4250006	4250005	4250004	4250002	4250000	4250003	4250010	4250011	
8	2640	1680	1232	973	377	298	231	193	155	124	99	77	58	41	
12	N/A	2520	1848	1459	566	447	347	289	233	186	148	116	87	61	
20	N/A	N/A	N/A	2553	990	782	606	505	408	326	259	202	152	106	
25	N/A	N/A	N/A	N/A	1226	969	751	626	505	403	321	250	188	132	

HYDRAULIC MOTORS

With choices from 0.7 cu. in. all the way to 45.6 cu. in. displacement, we have got the right hydraulic motor for your drilling job.

HYDRAULIC MOTORS

Motor	Displacement	P/N	Price
Danfoss	0.7 cu. in.	4250012	\$655
Danfoss	1.1 cu. in.	4250013	655
Danfoss	1.5 cu. in.	4250014	655
Danfoss	1.9 cu. in.	4250015	655
Char-Lynn	4.9 cu. in.	4250008	1080
Char-Lynn	6.2 cu. in.	4250007	1080
Char-Lynn	8 cu. in.	4250006	1080
Char-Lynn	9.6 cu. in.	4250005	1080
Char-Lynn	11.9 cu. in.	4250004	1080
Char-Lynn	14.9 cu. in.	4250002	1080
Char-Lynn	18.7 cu. in.	4250000	1080
Char-Lynn	24 cu. in.	4250003	1080
White	32 cu. in.	4250010	1280
White	45.6 cu. in.	4250011	1280



Motor	P/N	Price
A. Danfoss Motor	4250013	\$655
B. Char-Lynn Motor	4250007	1080
C. White Motor (shown with flow control valve)	4250010	1280
D. Flow Control Valve	4250019	499
E. Pillow Block & Spindle	4277539	739

AIR MOTORS

Description	Max CFM	P/N	Price
3.5 HP Ingersoll-Rand	95	4244051	\$5232
8 HP Ingersoll-Rand	230	4244052	6298



Ingersoll Rand - Motor & Pillowblock - \$5971
3.5 hp Ingersoll-Rand Air Motor (shown with pillow block)
P/N 4277539

DRILL RIG COLUMNS & MASTS



- Tremendous selection of mast/columns in lengths up to 120" long
- Greatly expanded stock
- Masts for angle and anchor rig configurations
- New M-4 anchor/swivel masts



COLUMNS & MASTS: M-1 & M-2

Description	P/N	Price
M-1 2-1/2" Square x 36" Long	4645084	\$125
M-1 2-1/2" Square x 42" Long	4645015	146
M-1 2-1/2" Square x 48" Long	4645081	166
M-1 2-1/2" Square x 60" Long	4645082	198
M-1 2-1/2" Square x 72" Long	4645083	239
M-1 Angle 2-1/2" Square x 36" Long	4645070	132
M-1 Angle 2-1/2" Square x 42" Long	4645068	152
M-1 Angle 2-1/2" Square x 48" Long	4645086	171
M-1 Angle 2-1/2" Square x 60" Long	4645085	202
M-2 2-7/8" Square x 36" Long	4641003	219
M-2 2-7/8" Square x 42" Long	4641002	256
M-2 2-7/8" Square x 48" Long	4641078	297
M-2 2-7/8" Square x 60" Long	4641079	365
M-2 2-7/8" Square x 72" Long	4641080	440
M-2 2-7/8" Square x 84" Long	4641084	511
M-2 2-7/8" Square x 96" Long	4641082	625
M-2 2-7/8" Square x 108" Long	4641083	704
M-2 2-7/8" Square x 120" Long	4644120	783
M-2 Angle 2-7/8" Square x 36" Long	4641089	224
M-2 Angle 2-7/8" Square x 42" Long	4641068	260
M-2 Angle 2-7/8" Square x 48" Long	4641091	297
M-2 Angle 2-7/8" Square x 60" Long	4641086	369
M-2 Angle 2-7/8" Square x 72" Long	4641087	443

COLUMNS & MASTS: M-3, M-4, M-5 & M-6

Description	P/N	Price
M-3 Stair 1-1/2" Square x 25" Long	4643001	\$116
M-3 Stair 1-1/2" Square x 33" Long	4643037	127
M-3 Stair 1-1/2" Square x 37" Long	4643033	141
M-3 Stair 1-1/2" Square x 41" Long	4643034	154
M-3 Stair 1-1/2" Square x 47" Long	4643032	172
M-3 Anchor 1-1/2" Square x 34" Long	4643002	105
M-3 Anchor 1-1/2" Square x 38" Long	4643006	116
M-3 Anchor 1-1/2" Square x 42" Long	4699923	127
M-4 Combo 1-5/8" x 2" x 30" Long	4600007	118
M-4 Combo 1-5/8" x 2" x 42" Long	4600034	292
M-4 Anchor/Swivel 1-5/8" x 2" x 30" Long	4600042	122
M-4 Anchor/Swivel 1-5/8" x 2" x 42" Long	4600047	156
M-5 Combo 2-1/2" x 3" x 32" Long	4600122	220
M-5 Combo 2-1/2" x 3" x 40" Long	4600106	255
M-5 Combo 2-1/2" x 3" x 50" Long	4600134	292
M-5 Combo 2-1/2" x 3" x 60" Long	4600123	366
M-5 Anchor 2-1/2" x 3" X 40" Long	4600115	255
M-5 Anchor 2-1/2" x 3" X 50" Long	4600135	292
M-5 Anchor 2-1/2" x 3" X 60" Long	4600127	366
M-6 3-7/8" x 5-7/8" x 72" Long	4640000	887
M-6 3-7/8" x 5-7/8" x 96" Long	4640042	1148
M-6 3-7/8" x 5-7/8" x 120" Long	4640063	1408

EXTENSIONS & ADAPTERS



Made of durable steel. On short notice, we can make any style adapter or extension rod to fit your needs!

ADAPTERS

Catalog No.	Top Thread	Bottom Thread Male	P/N	Price
1015	1.250"-7 Female	5-8"-11	4400008	\$34
1015B	1.250"-7 Female	5-8"-11 Bolt*	4400162	56
1510	5/8"-11 Female	1.250"-7	4400009	51
1016	1.250"-7 Female	5/8"-18	4400010	51
1020	1/2"-20 Female	5/8"-11	4400011	51
Bantum-15	Bantum Female	5/8"-11	4400012	51
Morse #2	#2 Morse Taper Male	5/8"-11	4400068	40
Morse #3	#3 Morse Taper Male	5/8"-11	4400061	46
Morse #4	#4 Morse Taper Male	5/8"-11	4400062	60
Morse #5	#5 Morse Taper Male	5/8"-11	4400063	89
3/8" S.S.	3/8" Straight Male Shank	5/8"-11	4400056	20
1/2" S.S.	1/2" Straight Male Shank	5/8"-11	4400033	20
5/8" S.S.	5/8" Straight Male Shank	5/8"-11	4400087	28
	1/2" BSP Male	5/8"-11	4400037	39
	1/2" BSP Male	1.250"-7	4400036	53
	1.875"-7 Female	1.250"-7	4400121	133
	1.250" Female	1.875"-7	4400134	133

BIT EXTENSION RODS

Length	Catalog No.	Fits Bit Size	Thread	P/N	Price
4"	125-4	1-5/8" - up	1.250"-7	4400001	\$35
4"	125-4 Water Sprayer	1-5/8" - up	1.250"-7	4400002	49
6"	120-6	up to 1-1/2"	5-8"-11	4400003	31
6"	125-6	1-5/8" - up	1.250"-7	4400004	42
12"	120-12	up to 1-1/2"	5-8"-11	4400005	43
12"	125-12	1-5/8" - up	1.250"-7	4400006	46
24"	125-24	1-5/8" - up	1.250"-7	4400042	80
36"	125-36	1-5/8" - up	1.250"-7	4400007	124
48"	125-48	1-5/8" - up	1.250"-7	4400024	139
6"	187-6	Optional Lg. Bits	1.875"-7	4400141	59
12"	187-12	Optional Lg. Bits	1.875"-7	4400113	89



Large selection in stock and ready for immediate delivery!



NOW AVAILABLE
"HOW TO"
DRILLING VIDEO
www.dynatech-diamond.com

ELECTRIC MOTORS



WEKA DK13 - \$1390
Hand held / portable. P/N 4244062



WEKA DK22/DK22S - \$1999
23 amp 3 speed 110V P/N 4244014



Husqvarna DM230 - \$1444
15 amp 3 speed 115V P/N 968411301



Core Bore CB748 - \$1204
Replaces B&D. P/N 4244000



Milwaukee 20 Amp - \$1138
P/N 4244032



WEKA DK42/DK42S - \$2599
Powerful 220V 3 phase. P/N 4244022

Need help selecting the right drill? Call us, we'll help. 1-800-446-9001

ELECTRIC MOTORS

Motor	AMP	RPM	Safety Override	P/N	Price
Core Bore CB748	20	350/900	Slip Clutch	4244000	\$1265
Husqvarna DM230 Hand Held	15	500/1400/2900	Slip Clutch	968411301	1444
Milwaukee 4004	20	300/600	Slip Clutch	4244032	1169
Milwaukee 4096	20	450/900	Slip Clutch	4244038	1169
Milwaukee 4005	20	600/1200	Slip Clutch	4244042	1169
WEKA DK13 Hand Held	14	580/1400/2900	Slip Clutch	4244062	1390
WEKA DK12 Hand Held	7 (220V)	580/1400/2900	Slip Clutch	4244013	1390
WEKA DK22	23	300/640/960	Slip Clutch	4244018	1999
WEKA DK22	11 (220V)	300/640/960	Slip Clutch	4244016	1999
WEKA DK22S	23	420/880/1300	Slip Clutch	4244014	1999
WEKA DK22S	11 (220V)	420/880/1300	Slip Clutch	4244029	1999
WEKA DK42	6 amp 460V-3PH	190/410/610	Slip Clutch	4244022	2651
WEKA DK42	13 amp 230V-3PH	200/420/630	Slip Clutch	4244023	2651
WEKA DK42S	6 amp 460V-3PH	290/605/910	Slip Clutch	4244027	2651
WEKA DK42S	13 amp 230V-3PH	290/610/910	Slip Clutch	4244024	2651
WEKA DK52	8 amp 460V-3PH	160/310/470	Slip Clutch	4244060	3117
WEKA DK52	16 amp 230V-3PH	160/310/470	Slip Clutch	4244061	3117

HYDRAULIC DRILLING

Husqvarna DM 406 HL 6-Speed Hydraulic Drill Motor \$4912

P/N 965158202

- 120-1,400 RPM
- 1-1/4" - 7 spindle thread
- Recommended bit diameter from 1" - 24"
- Weight - 35 lbs.
- Use PP418 or PP325E Hydraulic Power Pack



Husqvarna PP 418 \$5672

P/N 966947201

- Can power any hydraulic tool requiring 5, 8 or 10 gpm flow at 2,000 psi
- Unique hydrostatic pump system does not use engine rpm to regulate flow, providing more consistent and accurate flow at 5, 8 or 10 gpm
- 1/2" x 25' hose set (2 hoses) included

TECHNICAL SPECIFICATIONS

Engine	Gas twin cylinder OHV, air-cooled, electric start
Engine specification	Briggs & Stratton
Power, hp (kW)	18 (13.5)
Pressure, psi (bar)	2,000 (140)
Flow, gpm (lpm)	5, 8, 10 (20, 30, 40)
Weight (with oil), lbs (kg)	298 (135)
Hose set weight (with oil), lbs (kg)	22 (10)
Hose set (2 hoses included as standard)	1/2" (13cm) x 25 ft (7.5m)
hydraulic connections	Flat faced couplers with dust caps
Hydraulic oil capacity, gal (l)	4 (15)

Husqvarna Power pack PP325 E \$5980

P/N 965156406

The Husqvarna PP325 E is an electro-hydraulic power pack that is a simple and efficient, yet versatile, cart-mounted power pack that includes a tubular frame which protects components. The PP325 E can be easily transported and operated by one person. Includes 1/2" x 26' hose set (3 hoses).



TECHNICAL SPECIFICATIONS

Motor	Electric
Specifications	480 V, 16 amp, 60 Hz, 3 PH
Pressure, psi (bar)	2,000 (140)
Flow, gpm (lpm)	10 (40)
Output, hp (kW)	12.5 (9)
Weight (with oil), lbs (kg)	205 (93)

HAND HELD DRILL MOTORS



Technical Specifications	DM 230 3-Speed
Price	\$1,444
Motor output	1,725 W, 15 amp
Voltage	115V
Spindle speed - high	2,900 rpm full load
Recommended bit diameter	2" and under
Spindle speed - medium	1,400 rpm full load
Recommended bit diameter	2" - 4" bits
Spindle speed - low	580 rpm full load
Recommended bit diameter	4" - 6" bits
Maximum hole diameter	4" handheld, 6" rig mounted
Weight - lbs. (kg)	12 (5.4)
Spindle thread	1-1/4"-7; 5/8"-11
Handle style	Pistol grip
Carrying case	Included

Husqvarna DM 230

The Husqvarna DM 225 handheld core drill motor is ideal for drilling into concrete and masonry. This drill is suitable for professional operators, plumbers, electricians and contractors who demand performance and efficiency in a lightweight drill.

- Equally suited for wet or dry drilling
- Lightweight and powerful pistol grip design
- Softstart™ electronic current limiter ensures a soft start and less load on the electrical system
- Smartstart™ reduces the rpms by 50% when starting a new hole
- Elgard™ electronic slip clutch protects the motor and the operator

1-800-446-9001
WWW.DYNATECH-DIAMONDS.COM

ELECTRIC

If you drill a lot of holes, the WEKA DK13 is the drill for you.

WEKA DK13 - \$1390

- 3 speed motor (580/1400/2900)
- Very powerful (14 amps)
- Slip clutch (for safety)
- Built in water swivel (for wet drilling)
- Built in vacuum swivel (for dry drilling)
- Fits M-3 and M-4 drill stands
- P/N 4244062



HYDRAULIC

Hydraulic Motor - \$3234

- 3 speed motor (300/800/1600)
- 4 horse power
- Slip clutch
- Built in water swivel
- P/N 4244057
- Fits M-4 Drill Stand



PNEUMATIC

Pneumatic Motors

- 2 models:
 2.1 hp (300/500/1500) - p/n 4244054 - \$3008
 3.8 hp (190/420/805) - p/n 4244053 - \$3331
- Slip clutch
- Built in water swivel
- Fits M-4 Drill Stand



WATER & AIR SWIVELS

For Use on 1/2" Drills or Grinders

All 3 swivels have 5/8"-11 female thread so they will screw right on your 7" or 9" grinder or with 1/2" straight adapter (P/N 4400033) they can be used in your 1/2" drill. (Such as Hole Hawg or Timber Wolf.)



Air Vacuum Swivel - \$149
 1-1/4"-12 male thread
 for vacuum bits only
 P/N 4400125



Wet Cut Swivel - \$149
 1-1/4"-7 male thread
 P/N 4400013



Wet Cut Swivel - \$149
 5/8"-11 male thread
 P/N 4400014

HAND HELD DRILL MOTORS

HAND HELD DRILL MOTORS

DRILLING ACCESSORIES

VACUUM PUMPS

Gast, 1/8 hp, 24 hg vacuum pumps that mount easily and run quietly.

We have pumps designed for each of our rigs or choose a pump for an all purpose base.



VACUUM PUMPS

Description	Rig	Voltage	P/N	Price
With Fittings	M-1/M-2	110V	4244075	\$259
With Fittings	M-1/M-2	220V	4244076	312
With Fittings	M-3/M-4	110V	4244077	284
With Fittings	A.P.V. Base	110V	4244078	259

CONTROL PANELS



Dual Switch/Dual Outlet Amp Meter

With 3 red lines; 15, 18, 20 amp; 110V or 220V models.



Single Switch/Dual Outlet Amp Meter

With switch controls motor outlet and vacuum pump outlet. Amp meter, has 3 red lines; 15, 18, 20 amp. 110V or 220V models.

CONTROL PANELS

Control Panel	Features	Voltage	P/N	Price
Dual Switch/Dual Outlet	Amp Meter	110V	4243000	\$177
Dual Switch/Dual Outlet	Amp Meter	220V	4243075	209
Single Switch/Dual Outlet	Amp Meter	110V	4277537	166
Heavy Duty On/Off Switch	Amp Meter	110V	4244021	54
Heavy Duty On/Off Switch	Amp Meter	220V	4243021	54

Optional On/Off Switch

For CB748 or Milwaukee Motors.
110V p/n 4244021 **\$54**
220V p/n 4243021 **\$54**

HILTI ADAPTERS

Allows all core bits to be used on Hilti machines.



For Hilti machines:
DD130 with BI+ style core bit connection

List Price - \$37.26
P/N 4400333
Hilti Q.D. Male to 5/8-11 Male Thread (6 Slot)



For Hilti machines:
DD130 with BI+ style core bit connection

List Price - \$46.09
P/N 4400332
Hilti Q.D. Male to 1-1/4-7 Male Thread (6 Slot)



For Hilti machines:
DD250, DD160, DCM1.5 with BU style core bit connection

List Price - \$266.00
P/N 4699973
1-1/4-7 Male Thread to Hilti Spline



For Hilti machines:
DD200

List Price - \$270.00
P/N 4699992
Female Spline to 1-1/4-7 Male Thread

For Hilti machines:
DD200, DD160, DCM1.5 with BU style core bit connection

List Price - \$266.00
P/N 4699974
5/8-11 Male Thread to Hilti Spline



CORE RIG SPACER BLOCKS



M-1 Spacer Block - \$66
Adds 4" of drilling capacity
P/N 4400072



M-2 Spacer Block - \$87
Adds 4" of drilling capacity
P/N 4400073

DRILLING ACCESSORIES

Pipe Mount Adapter

- Works on any Core Bore rig
- Can be used on any size pipe
- Comes complete with base plate, tie-down strap and hardware
- Bit capacity depends on rig being used
- Specify Core Rig Model



Pipe Mount Assembly - \$213
P/N 4400509

NOW AVAILABLE
**"HOW TO"
DRILLING VIDEO**
www.dynatech-diamond.com

WATER / DUST CONTROL



WT 10 Pressurized Water Tank With Ion Re-chargeable battery- \$289
P/N 965971002



Water tank (plastic - 4 gal.) - \$74
P/N 506326302

Water tank (metal - 4 gal.) - \$144
P/N M30093



E-350 Water Trap Ring and Teel Pump - \$137
P/N 4400015

OTHER ACCESSORIES



Vacuum Plate w/Wheels - \$220
Converts anchor base to vacuum base.
Fits M-1, M-2 & M-3 anchor bases.
P/N 4247075



Bit Sharpening Pot - \$117
Resharpens diamond bits fast & easy. Up to 8" bit capacity. P/N 4400022



Slider Bit Quick Disconnect 1-1/4" for easy bit removal - \$59
P/N 541400280



50' Cord - \$92
12GA 115V 20A
Twist to 15A Straight
P/N 4699100

WATER / DUST CONTROL & OTHER ACCESSORIES

Description	P/N	Price
E-400F Metal Water Pressure Tank with Fittings	4400021	\$169
E-400 Metal Water Pressure Tank without Fittings	2600042	127
E-350 8" Water Collector Ring and Teel Pump (115V)	4400015	137
E-350 8" Water Collector Ring and Teel Pump (230V)	4400201	147
E-150 8" Trap Ring Only	4400016	56
E-250 Wet/Dry Vacuum Hose Adapter	4400017	32
E-300 Dry Trap for Dry Drilling (specify size - 8" max)	4400018	89

DRILLING ACCESSORIES

CORDS & ACCESSORIES

CORDS

Description	P/N	Price
Power Cord - 100ft 10GA 15A Plug w/3way 15A receptacle	150360	\$109
Power Cord - 100ft 10GA 15A Plug w/20A Twistlock (L5-20R) receptacle	150878	129
Power Cord - 50ft 10GA 15A Plug w/3way 15A receptacle	150810	69
Power Cord - 50ft 10GA 15A Plug w/20A Twistlock (L5-20R) receptacle	150879	84
Generator Power Cord - 75ft 10GA 30A Twistlock (L5-30P) Plug w/3way 15A receptacle	150827	109
Generator Power Cord - 75ft 10GA 30A Twistlock (L5-30P) Plug w/20A Twistlock (L5-20R) rec.	150880	124
Generator Plug - 30A 115V L5-30P Twistlock	150809	29
GFCI Cord - 3ft 12GA 15A w/3way receptacle	150828	59
Adapter Cord - 1ft 12GA 15A Plug x 20A Twistlock (L5-20R) receptacle	120009	34
Adapter Cord - 1ft 12GA 15A Receptacle x 20A Twistlock (L5-20R) plug	150868	30
Adapter Cord - 1ft 12GA 30A Twistlock (L5-30P) Plug w/3way 15A receptacle	150359	99



Power Cord



Red Generator



Adapter Cords

PLATED HOLE SAW BITS

Electroplated Diamond Bits for Tile, Stone and More

Materials:

- Tile - all types
- Fiberglass
- Marble • Pottery
- Granite • Mirror
- Glass • Slate

Applications:

- Faucet Installations
- Toilet Anchors
- Towel Bars
- Plumbing Pipe Holes
- Shower Doors
- Electrical Outlets
- Shelving Brackets
- and More!

10 Piece Set with
Universal Guide - \$155
P/N 03287



14 Piece Set with
Universal Guide - \$290
P/N 04258



5 Piece Set with
Universal Guide - \$58
P/N 04257

Universal guides can help you keep your bit straight and aligned with your desired drilling spot.

Plated Hole Saw Bits Easily Fit Into Standard Rotary Drills and Are Simple To Use

Suction Rings - \$13

P/N 03288

These trap rings prevent the use of putty dam. Putty dam is clay or putty rolled into a ring to prevent water from escaping the drilling area. This can be messy and time consuming. Water trap rings are recommended for keeping your drilling area cleaner.



Plated hole saw bits are selfsharpening. You get the entire life of the diamond due to the electroplated technology.

Plated Hole Saw Bits (Individual)

Size	P/N	Price
1/8"	04235	\$5
1/4"	04236	8
3/8"	04237	12
1/2"	04239	18
1"	04240	19
1-1/4"	04241	22
1-3/8"	04243	26
1-1/2"	04248	28
2"	04250	36
2-1/4"	04251	42
2-3/8"	04253	53
2-1/2"	04254	56
3"	04255	60

Plated Hole Saw Sets

Description	P/N	Price
5 piece set with universal guide	04257	\$58
10 piece set with pilot adapter	03287	155
14 pieces set with guide, water bottle	04258	290
suction rings 1-1/2" & 3" set	03288	13



Core Catcher Assembly - \$163

P/N 4400327

Attaches to spindle on the top end and an eyebolt is anchored into the core. The cable is attached to the eye-bolt or hook.

Includes: Spindle adapter and catcher cable

The cable is inserted down the sides of the core. The cable clings to the core as the rings are pulled by hand or lifted by other means.

DRILLING ACCESSORIES

Anchoring System

Steel Drop-in

A carbon steel machine bolt anchor that can be used in solid concrete, hard stone and solid block. For anchoring core drilling and wall sawing equipment. Carbide drill bits should be 1/8" or next size larger than the drop-in anchor size.

Part No.	Accessory	Box of 50	Carton of 250
150883	1/2" - 13	\$26	\$98

Pro Fastnut



Heavy Sq. Washer

Accessory	Part. No.	List
Pro Fastnut 1/2" - 13	150327	\$45
Heavy Square Washer 1/2"	150615	\$3

SETTING TOOLS

Part No.	Size	1 Each
150887	1/2"	\$5



Lock-Bolt®

Pre-assembled single unit sleeve anchor available in carbon steel for concrete, block, brick and stone. Extension sleeves are added to create longer lengths. Used with core drills and wall saws. Carbide drill bit diameter needs to match the Lok-Bolt™ size.



Part No.	Accessory	Qty. & Price	Qty. & Price
150895	1/2" x 4"	Box of 25 = \$23	Box of 125 = \$79
150917	1/2" x 6"	Box of 10 = \$18	Box of 100 = \$144

SDS-Max®

SDS-Max Carbide Drill Bits are for use in a rotary hammer equipped with a SDS-MAX® type chuck for concrete, block, brick and soft stone.



SDS Plus®

SDS-Plus Carbide Drill Bits are for use in a rotary hammer equipped with an SDS (slotted drive shaft) type chuck and can be used to drill in concrete, block, brick and soft stone.



Spline

For rotary hammers equipped with a spline type chuck for concrete, block, brick and soft stone.

Part No.	Accessory	1 Each
150905	1/2" x 13" SDS MAX	\$35
150919	1/2" x 12" SDS PLUS	\$12
150908	1/2" x 13" SPLINE	\$30



Wedge-Bolt® Blue Tip

One piece heavy duty anchor with a finished hex head. It is easy to identify, removable and vibration-resistant. Used in solid concrete. Reusable on core drills and wall saws. Wedge-Bolt anchors must be installed with a Wedge-Bit. The Wedge-Bit has a special matched tolerance range designed to provide optimum performance for the anchor.

Part No.	Accessory	Box of 50	Carton of 150
150896	1/2" x 4	\$130	\$273

Wedge Bit Blue



Part No.	Accessory	1 Each
150899	1/2" x 13" SDS MAX	\$62
150911	1/2" x 12" SDS PLUS	\$23
150902	1/2" x 13" SPLINE	\$44



Hollow-Set™ Drop-in

Designed for anchoring in hollow base materials such as hollow concrete block, brick with weep holes and hollow core pre-cast concrete plank. Also for solid base materials.

Part No.	Accessory	Box of 50	Carton of 250
150885	1/2" - 13	\$115	\$402

SETTING TOOLS

Part No.	Size	1 Each
150889	1/2"	\$14

SLURRY SLURP

The perfect solution to a messy problem

The Slurry Slurp is a patented shop vacuum attachment that has been engineered to contain and remove the water and slurry created during concrete drilling. The Slurry Slurp is manufactured as one molded piece and comes complete with vacuum hose.



5 inch model - \$109
for core bits up through 5"
P/N SS5

10 inch model - \$150
for core bits from 5" to 10"
P/N SS10



Price includes Slurry Slurp body, gasket set, and 10 foot vacuum hose with cuffs and instructions

- Contains and removes water and slurry generated during core drilling. Prevents staining of walls and floors.
- Saves at least 10 to 15 minutes on every hole cut.
- Installs in seconds – Just connect it to your wet/dry vacuum.
- Delivered complete with 12 feet of special vacuum hose – no additional tools are needed.
- Molded from a durable, lightweight polymer for trouble-free maintenance
- Patented design allows the Slurry Slurp to be self-attaching to concrete walls (with over 35 lbs. of force) and floors using only the suction from the wet/dry vacuum. No other attachment hardware is needed. Attaches in seconds.
- Supplied in two sizes for drilling holes up to 10 inches.



DYNATECH APPAREL

\$9.99 ea.
or
FREE
WITH INTERNET
ORDER

1-800-446-9001
WWW.DYNATECH-DIAMONDS.COM

Long Sleeve T-Shirt

Sizes: S, M, L, XL, XXL
(Black only)



FRONT



BACK

Short Sleeve T-Shirt

Sizes: S, M, L, XL, XXL
(Grey only)



FRONT



BACK



DYNATECH

DIAMONDS AT WORK

P.O. Box 1589 Elyria, OH 44036
Phone: 1.800.446.9001 • 440-365-1774 • Fax: 440-365-1717
E-Mail: dynatech@windstream.net
www.dynatech-diamond.com